

# Associated Intrinsically Safe Alarm Trip

Class 1, Div 1/Zone 0

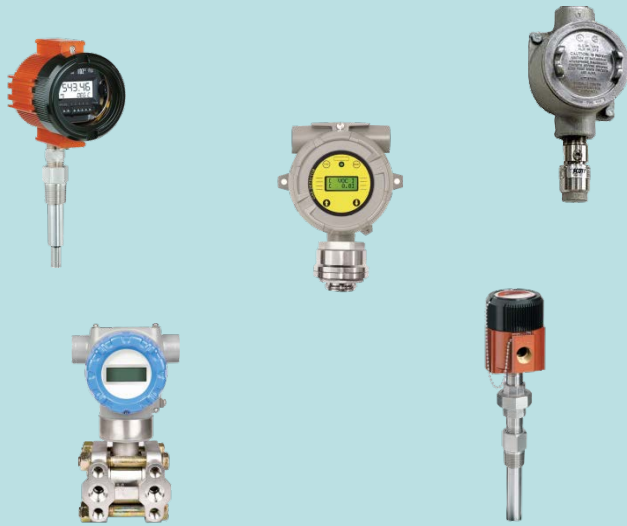

Class 1, Div 2/Zone 2 or  
General Location

IS barrier  
inside

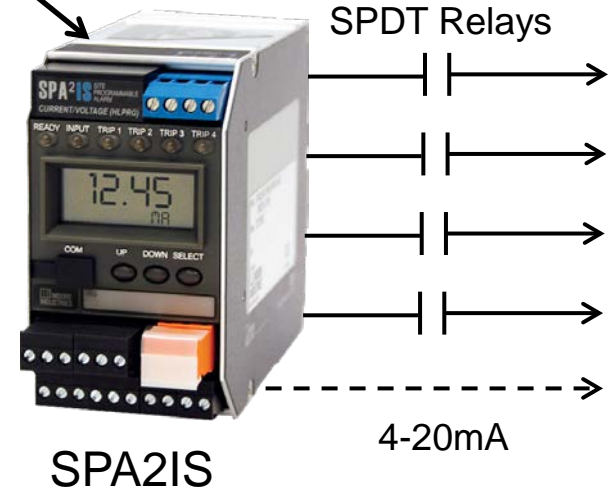

No IS Barrier  
Required

# High Availability Alarm System: 2oo3 Voting

Trip Amp Relays  
wired for 2oo3  
Voting

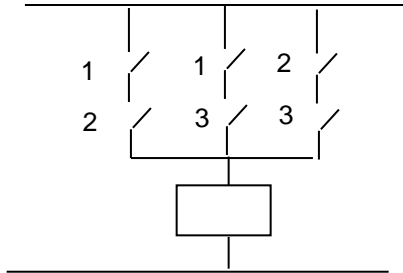

SPA2  
Alarm Trips

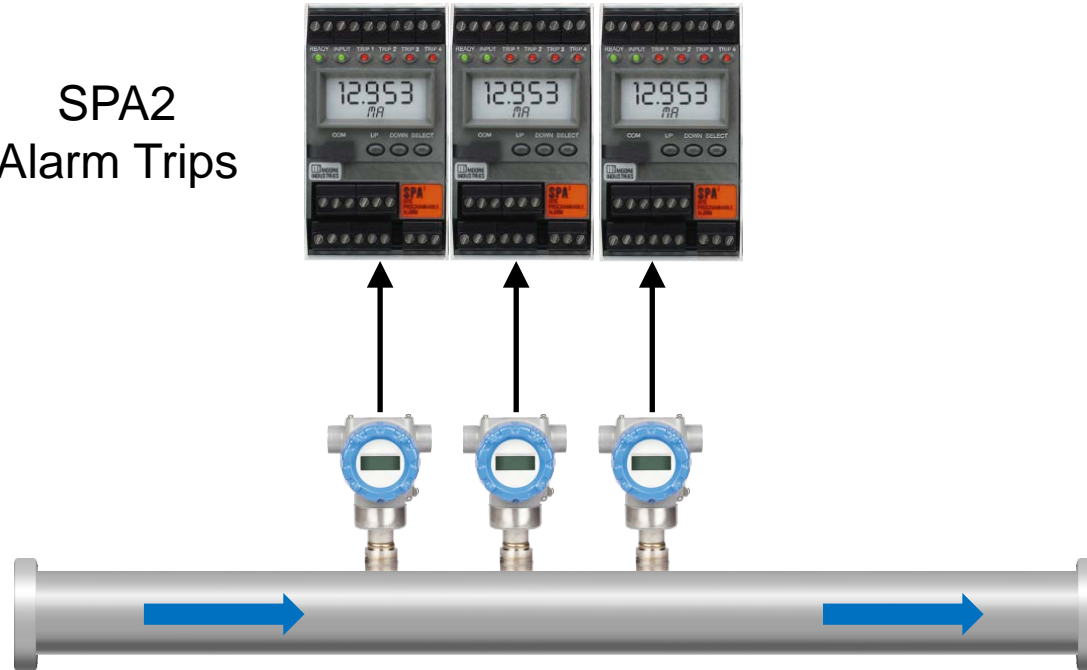

# Pressure Protection – Alarm Trip

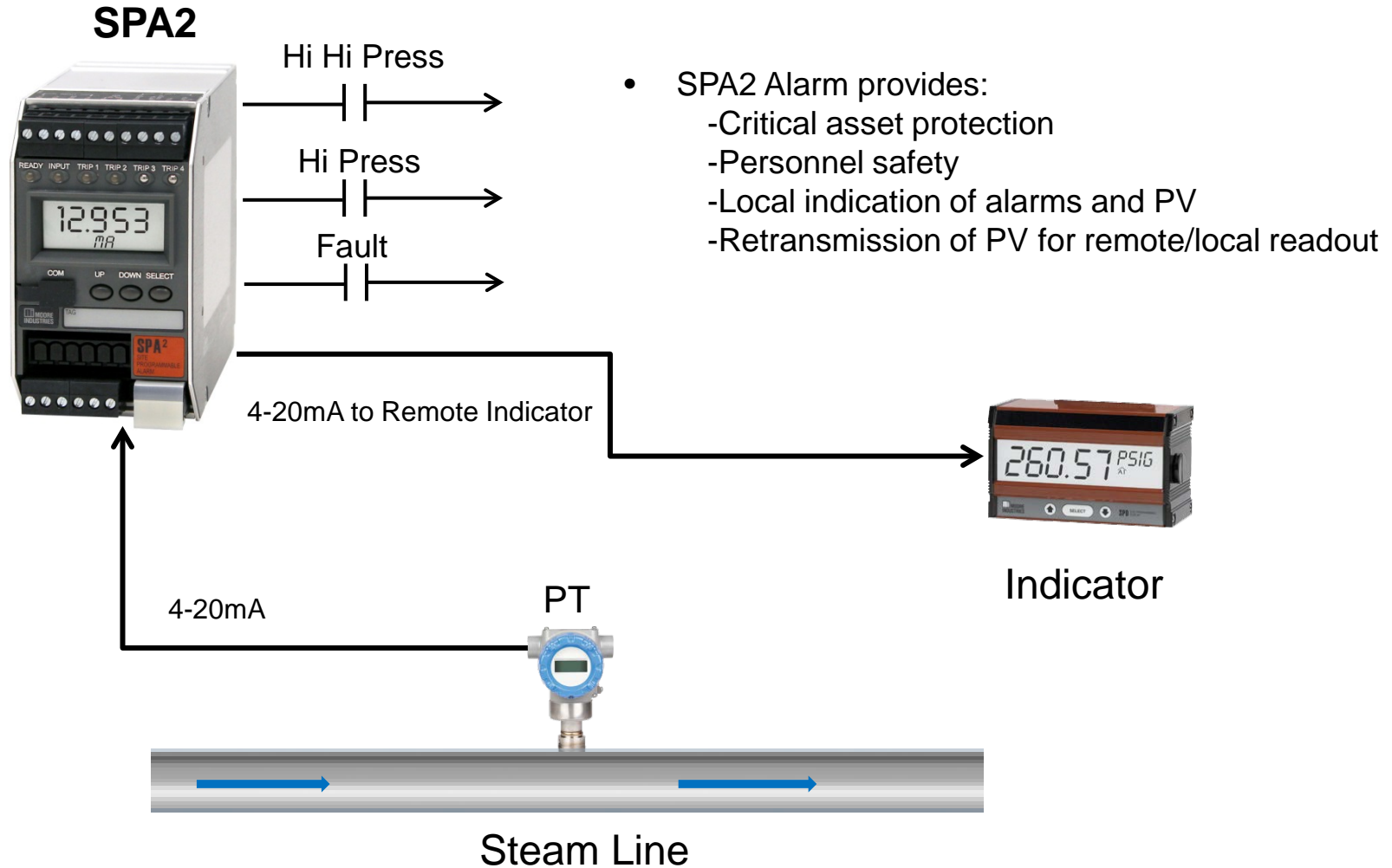

# HART Interface Module and HART Mux

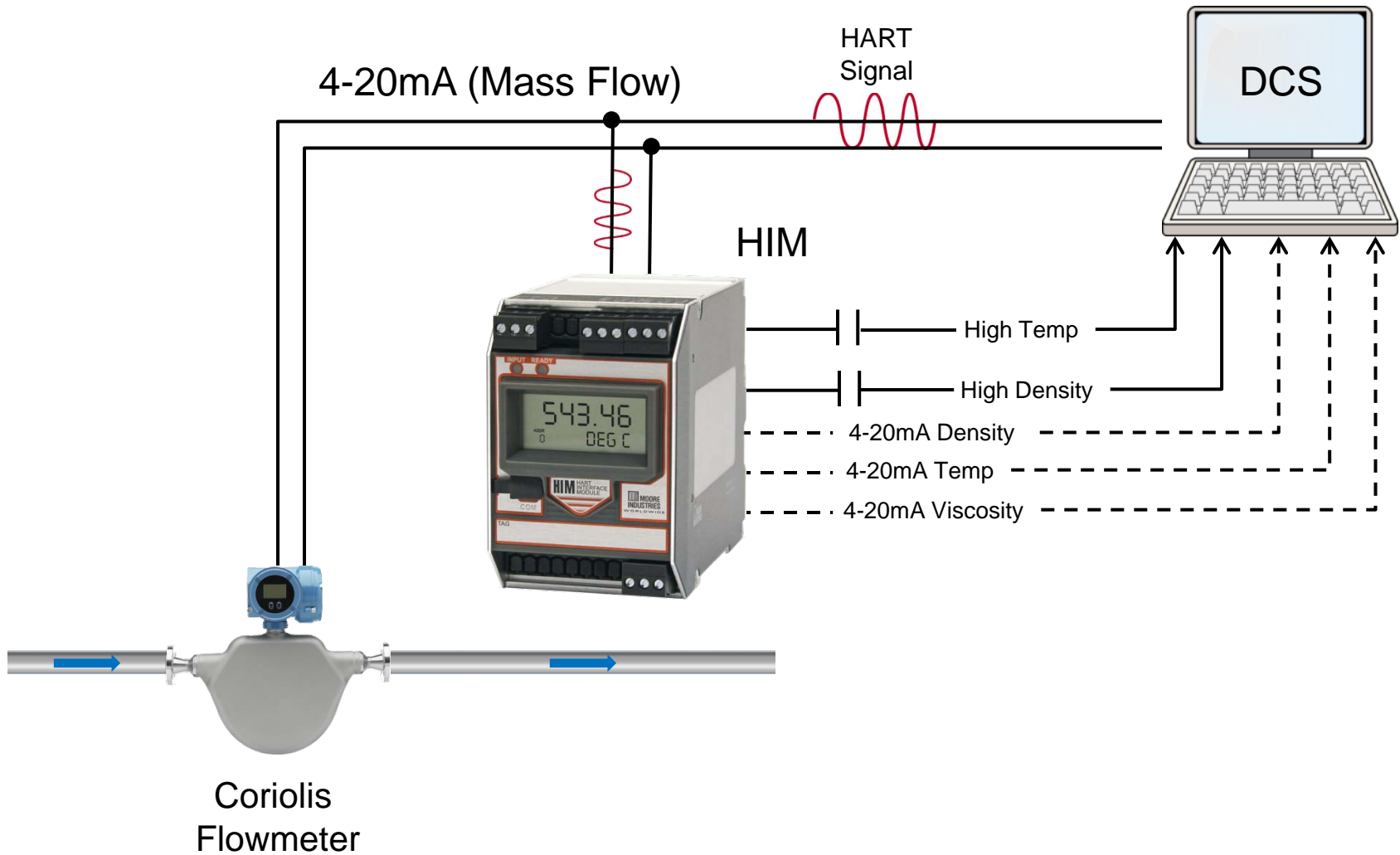

# HART to MODBUS Gateway

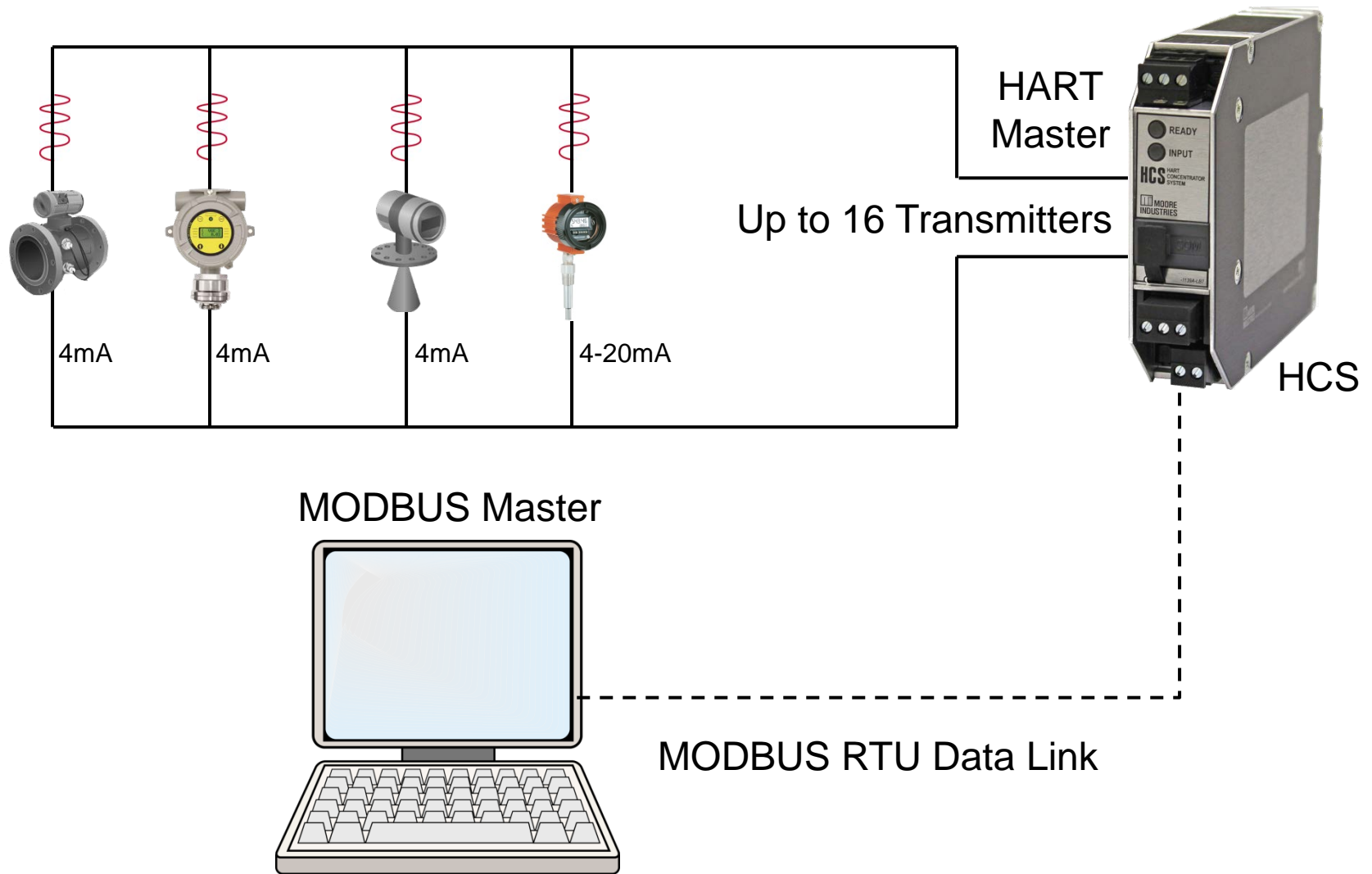

# HART to MODBUS Gateway – Smart Valves

Use the HCS (HART to Mbus)  
Monitor Multiple Critical Valves  
via MODBUS RTU

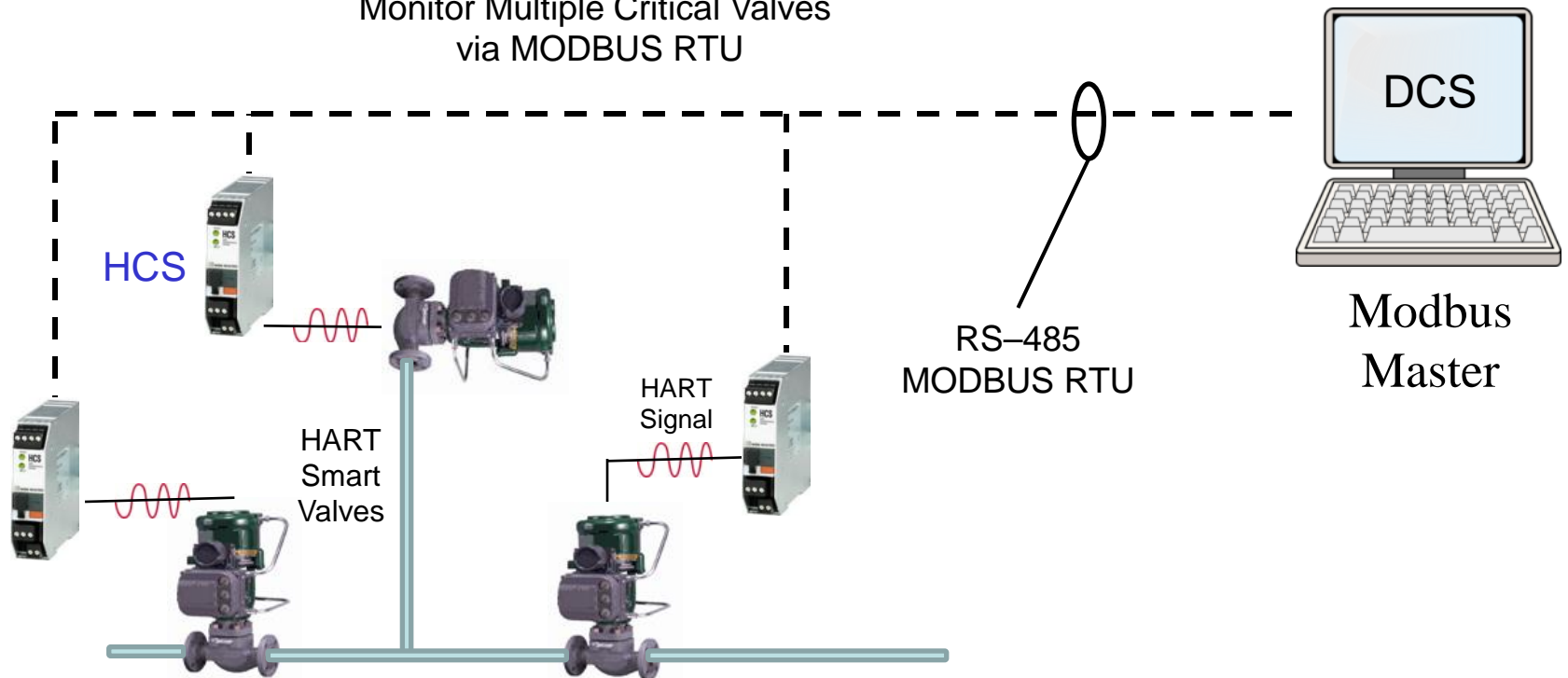

# HART Mux – Smart Valve Diagnostics

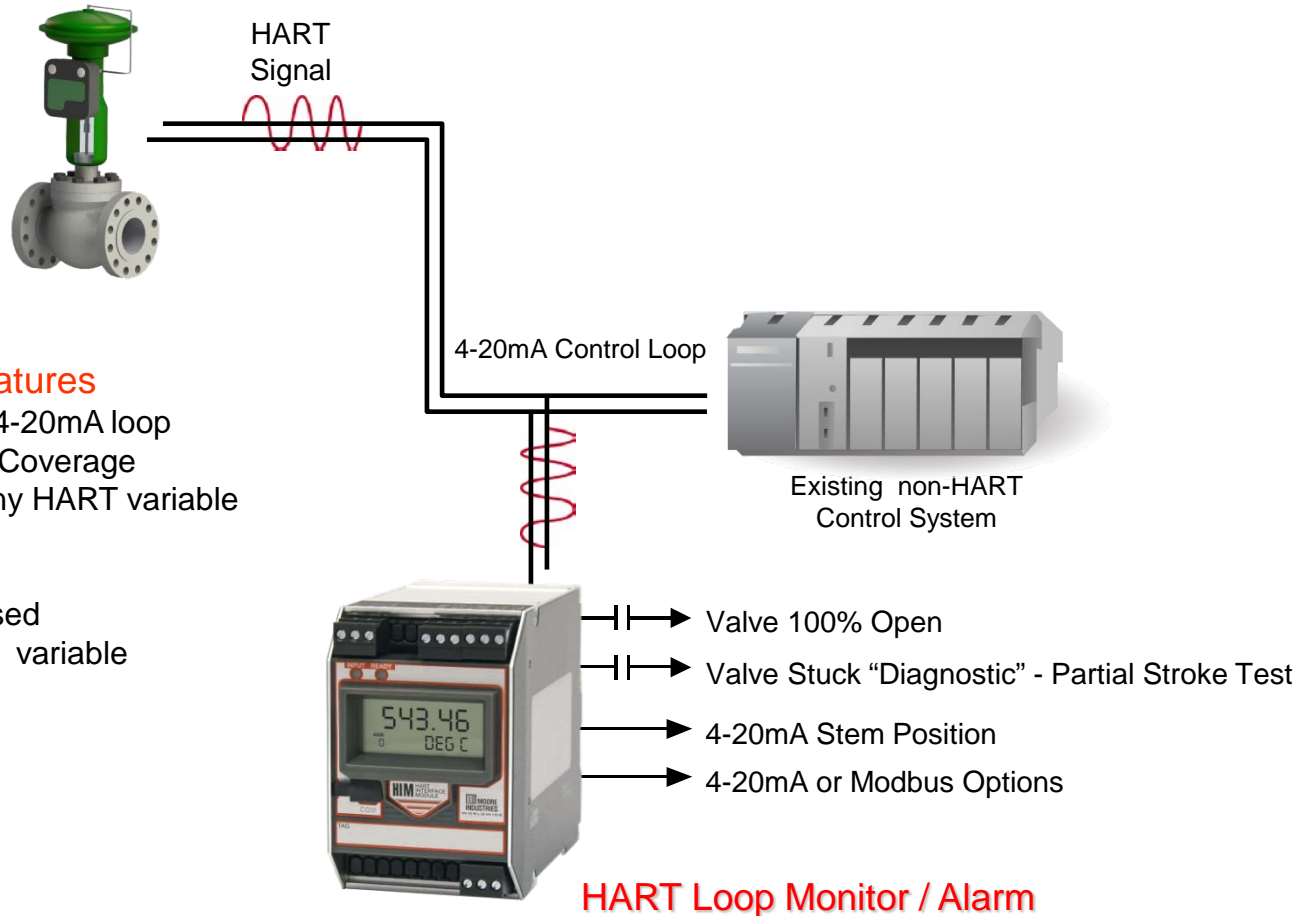

## HART Monitoring Features

- Non-intrusive across 4-20mA loop
- Increases Diagnostic Coverage
- 4-20mA Output for any HART variable
- Optional relays for:
  - Positioner Health
  - Valve open or closed
- Display for any HART variable
- Fully PC configurable
- Saves extra cabling

# SIL 3 Capable Logic Solver – Pressure

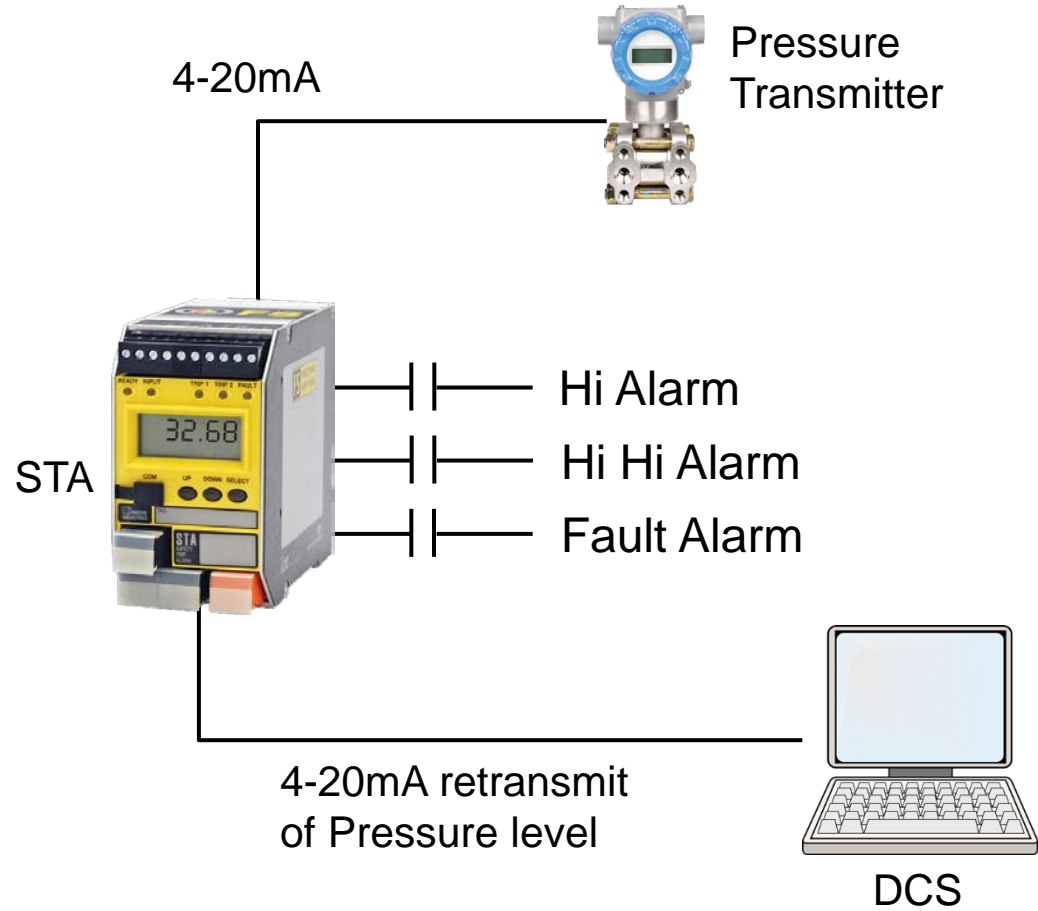



# IEC 61508 Certified SIL 3 Capable Signal Isolator/Repeater

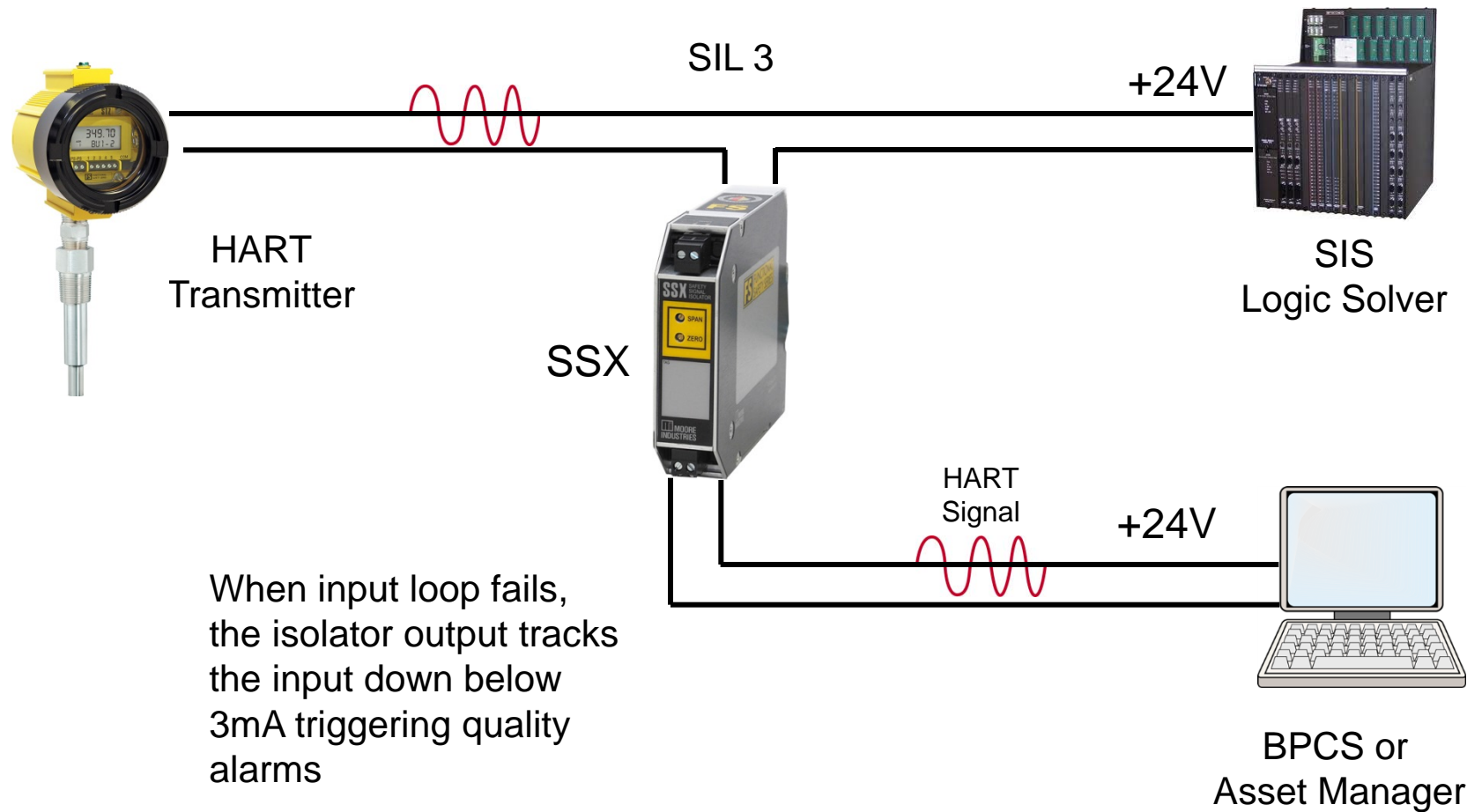

# Critical Flow Monitoring – Safety Signal Splitter

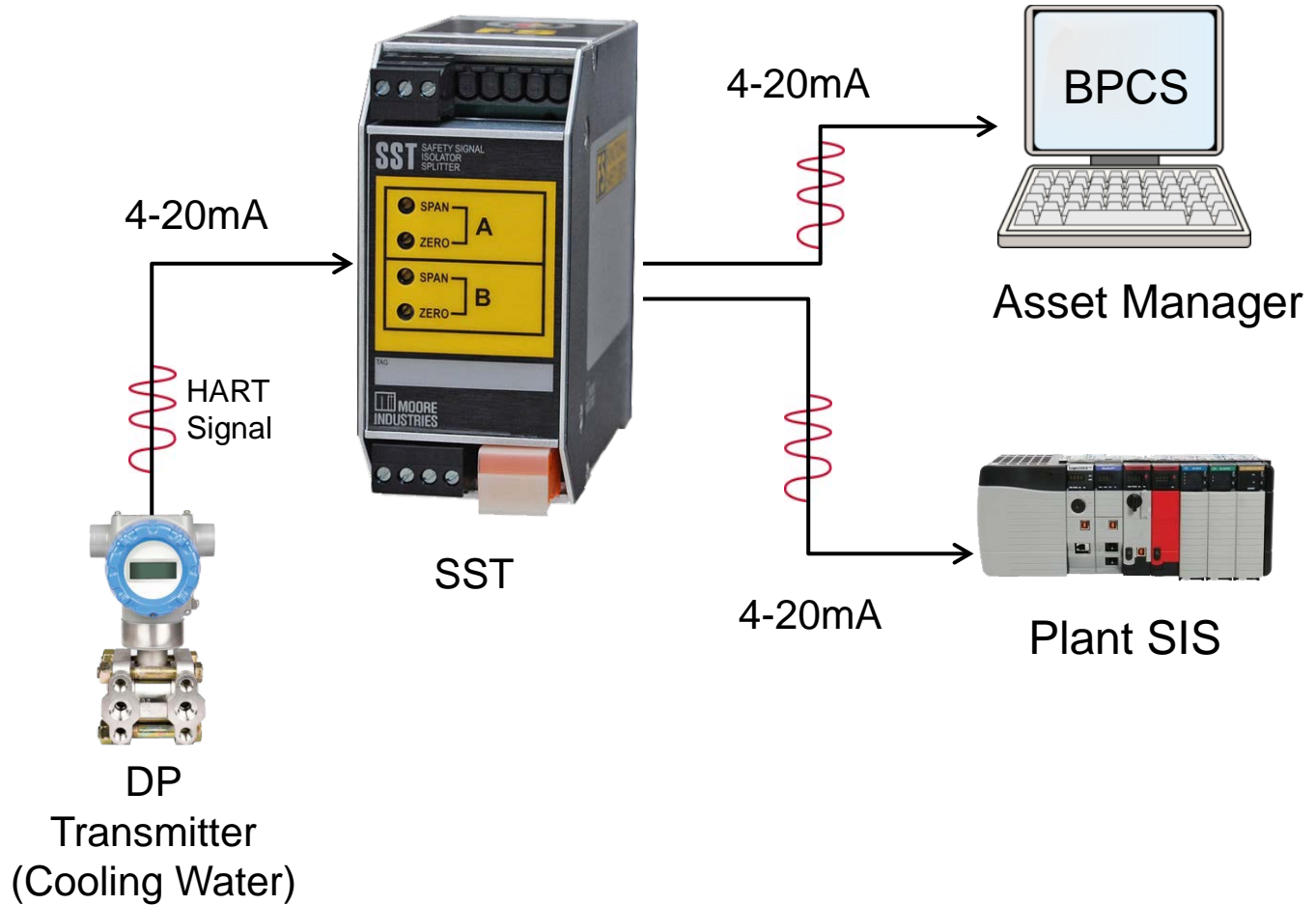

# SIL 3 Capable Temperature Transmitter

STZ  
Temperature Transmitter



HART  
Signal



+24V

SIS  
Logic Solver

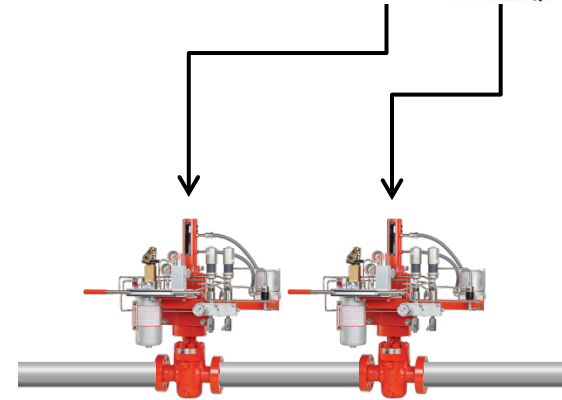

ESD  
Valves



# SIL 3 Capable Frequency to DC Converter

## Compressor Over-speed Protection

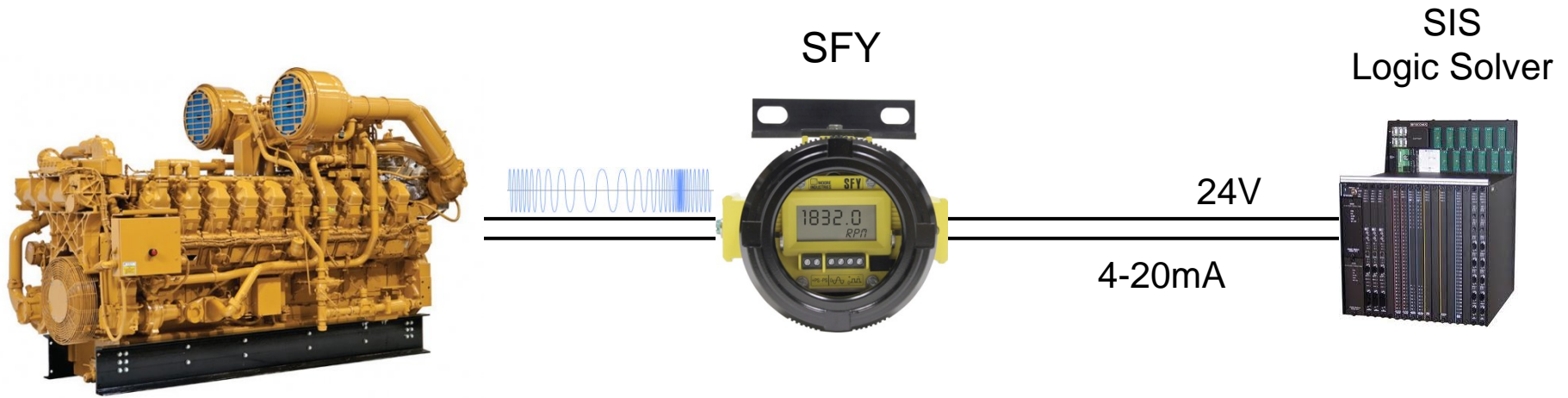

### IEC 61508 Certified Frequency / Speed transmitter

- High Accuracy Frequency to 4-20mA
- Input Spans: 0.1 Hz to 25,000Hz
- Accuracy: 0.01 to 0.05% of reading
- Hazardous area certified
- Ambient: -40°F to 185°F

# IEC 61508 Certified SIL 3 Capable Loop Display

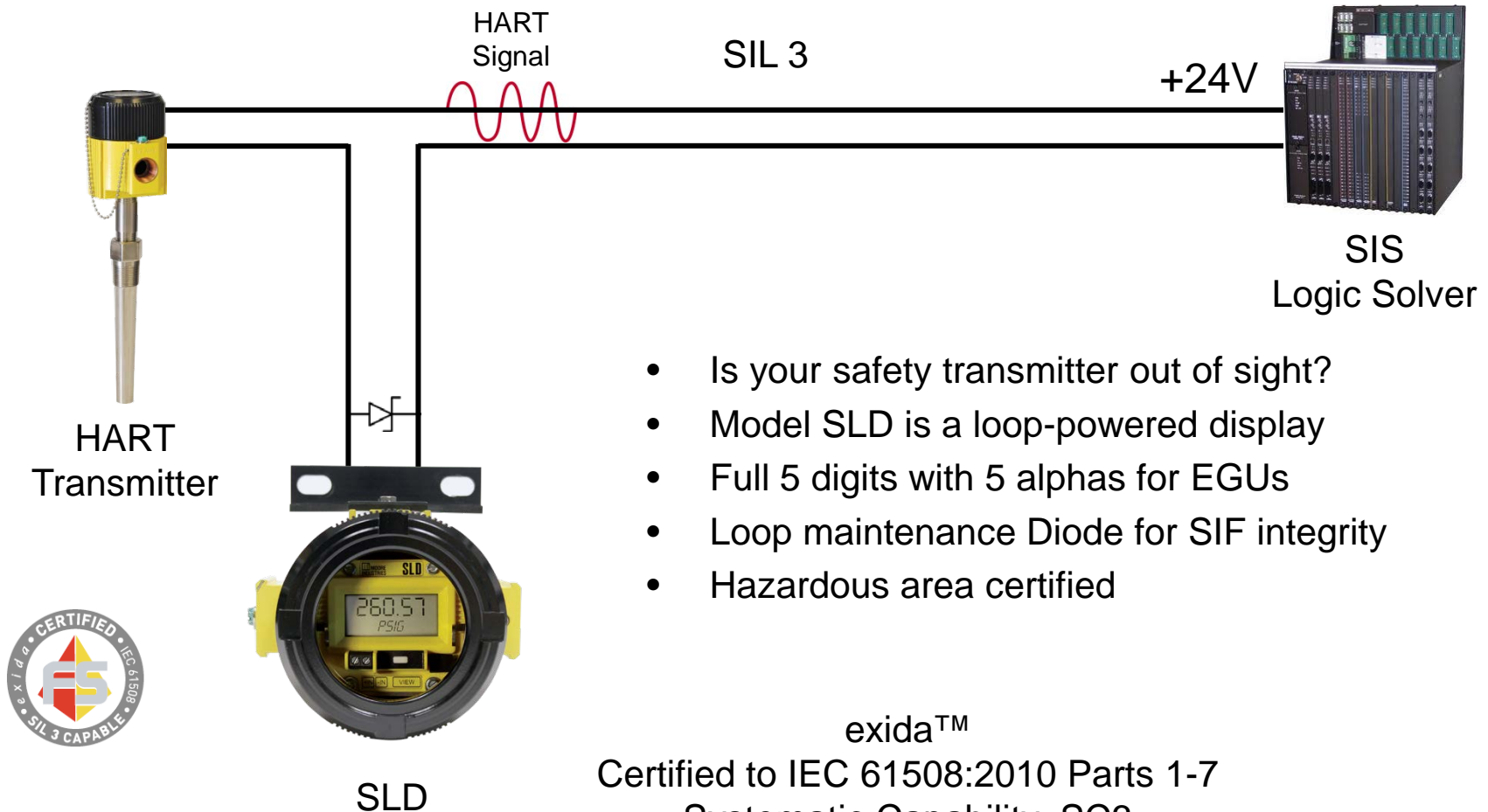

- Is your safety transmitter out of sight?
- Model SLD is a loop-powered display
- Full 5 digits with 5 alphas for EGUs
- Loop maintenance Diode for SIF integrity
- Hazardous area certified

exida™  
Certified to IEC 61508:2010 Parts 1-7  
Systematic Capability: SC3  
Random Integrity: Type A Non-interfering

# Field Mount Loop Indicator/Display

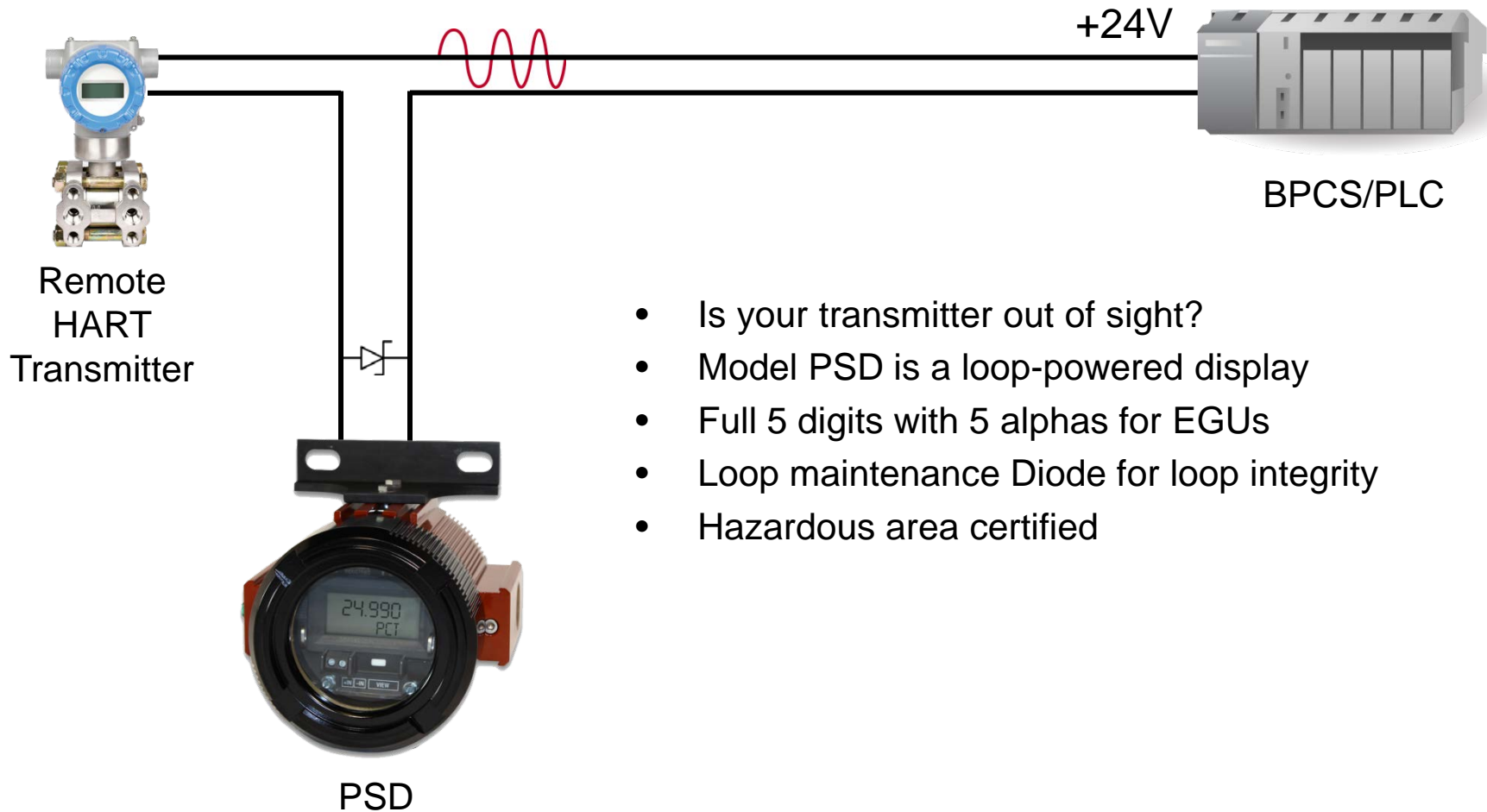

# Large Field Mount Loop Indicator/Display

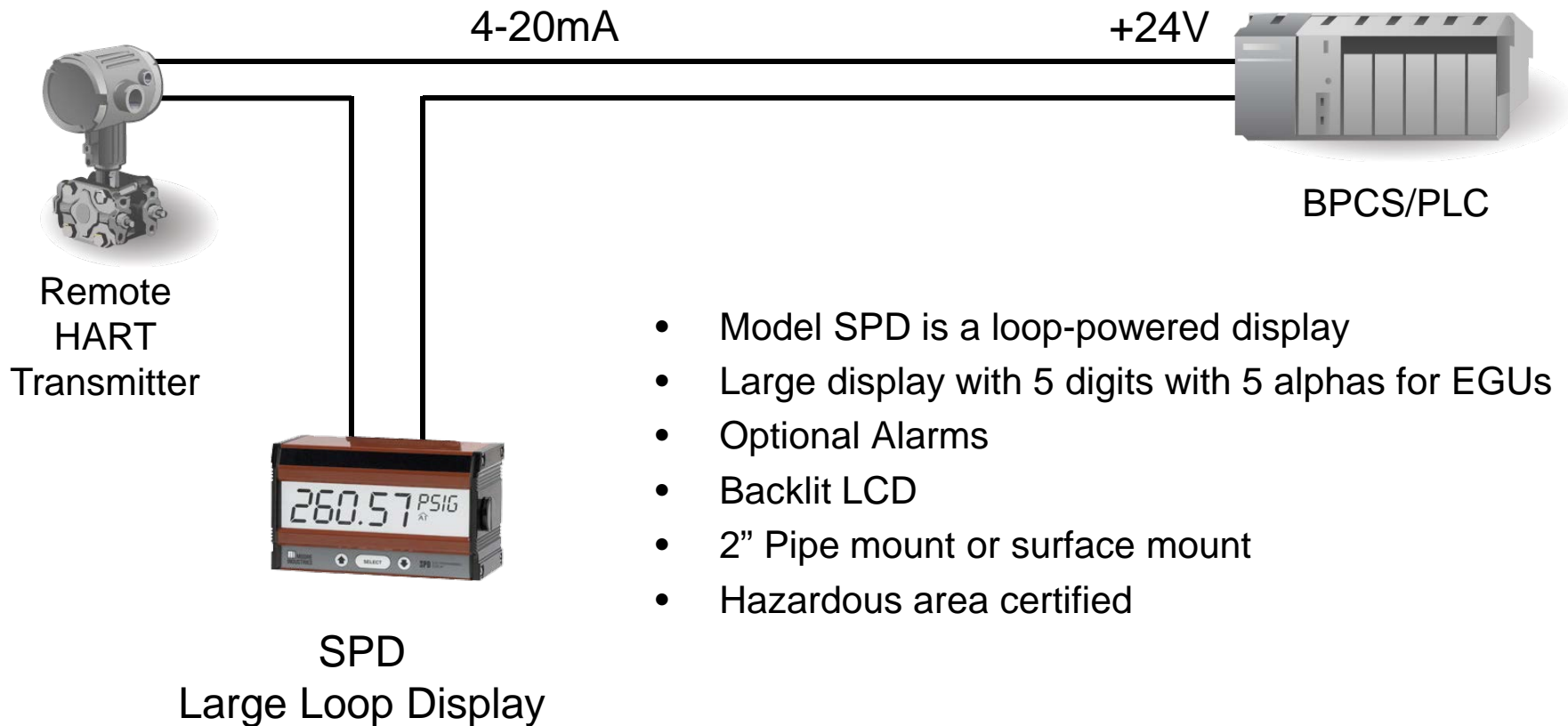

# 1/8 DIN Panel Display/Meter



Nema 4X Panel



## 330R

1/8 DIN Panel Meter & Alarm